

# **KIT ELEVADOR ELECTRÓNICO**

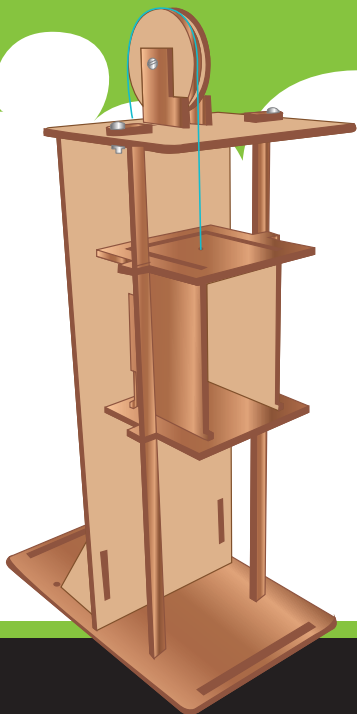

# IMPORTANTE

Antes de utilizar su nuevo producto Steren, lea este manual para evitar cualquier mal funcionamiento.

La información que se muestra en este manual sirve únicamente como referencia sobre el producto. Debido a actualizaciones pueden existir diferencias. Por favor, consulte nuestra página web [www.steren.com](http://www.steren.com) para obtener la versión más reciente del manual.

## PRECAUCIONES:

- NO apriete demasiado los tornillos para evitar dañar o romper las piezas.
- Tenga cuidado al ensamblar las piezas, NO las fuerce.
- Use pegamento para madera para fijar las uniones del armado. Evite colocar pegamento en las partes móviles.
- Este aparato no se destina para utilizarse por personas (incluyendo niños), cuyas capacidades físicas, sensoriales o mentales sean diferentes o estén reducidas, o carezcan de experiencia o conocimiento.
- Los niños deben supervisarse para asegurar que no empleen el aparato como juguete.

## HERRAMIENTAS NECESARIAS

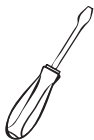

Desarmador plano

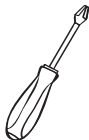

Desarmador de cruz



Pegamento para madera



Pinzas de punta

# CONTENIDO





## PIEZAS DEL CHASIS

**!** Maneje las piezas con cuidado, pueden romperse facilmente.

A	Cant.
	1 pza.

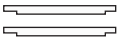
B	Cant.
	1 pza.

C	Cant.
	2 pzas.

D	Cant.
	2 pzas.

E	Cant.
	2 pzas.

F	Cant.
	1 pza.

G	Guías	Cant.
		2 pzas.

H	Cant.
	2 pzas.

I	4.2 cm de diametro	Cant.
		1 pza.

J	Cant.
	2 pzas.

K	Cant.
	2 pzas.







L	4.7 cm de diametro	Cant.
		2 pzas.

M	Cant.
	1 pza.







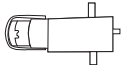

N	1.7 cm diametro	Cant.
		2 pzas.

Ñ	1.5 cm diametro	Cant.
		1 pza.

O	1.2 cm diametro	Cant.
		1 pza.

<b>P</b>		Cant. 2 pzas.
<b>Q</b>	Tuerca de seguridad 	Cant. 1 pza.
<b>R</b>	Cable dupont 	Cant. 1 pza.
<b>S</b>		Cant. 8 pzas.
<b>T</b>	Tornillo grande 	Cant. 3 pzas.
<b>U</b>	Tornillo chico 	Cant. 6 pzas.
<b>V</b>	Hilo de nylon 	Cant. 1 pza.
<b>W</b>	Motorreductor 	Cant. 1 pza.

## PIEZAS DE LA TARJETA

<b>J2</b>	Header 	Cant. 1 pza.
<b>Q1 - Q4</b>	Transistor 2N 2222 	Cant. 4 pzas.
<b>J1</b>	Broche pila 	Cant. 1 pza.
<b>R1 - R4</b>	Resistencia 560 (verde, azul, café) 	Cant. 4 pzas.
<b>S1 - S2</b>	Botón tipo push 	Cant. 2 pzas.
<b>R5 - R6</b>	Resistencia 3K9 (naranja, blanco, rojo) 	Cant. 2 pzas.
<b>D1 - D4</b>	Diodo 1N4148 	Cant. 4 pzas.
<b>D5 - D6</b>	LED rojo 	Cant. 2 pzas.

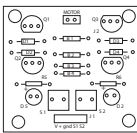
<b>PCB</b>	Placa 	Cant. 1 pza.
------------	---	-----------------



Arme y suelde los componentes de la placa como se indica en la imagen.

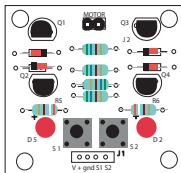

Algunos componentes tienen polaridad tenga cuidado.

# ENSAMBLAJE

Comience a ensamblar desde la base.



Asegúrese de colocar las piezas correctas antes de aplicar pegamento.

1

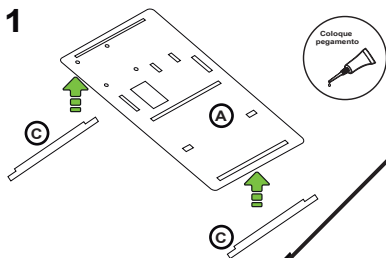

2

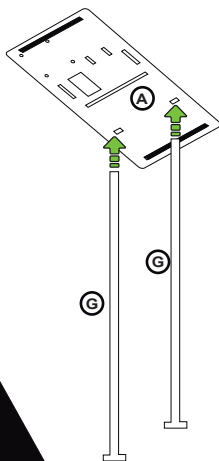

Pase las piezas G por debajo de la pieza A con cuidado.

3

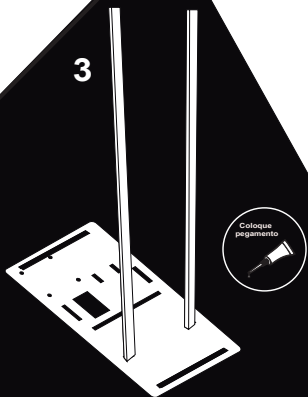

#### 4 Arme la cabina del elevador

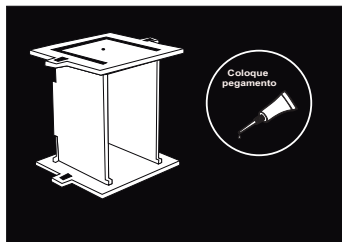
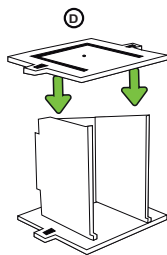
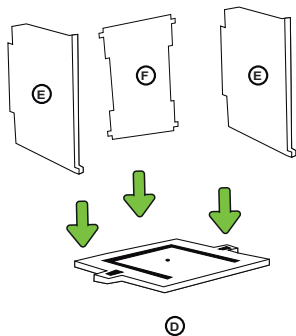

5

! Tenga cuidado de no dañar las piezas G

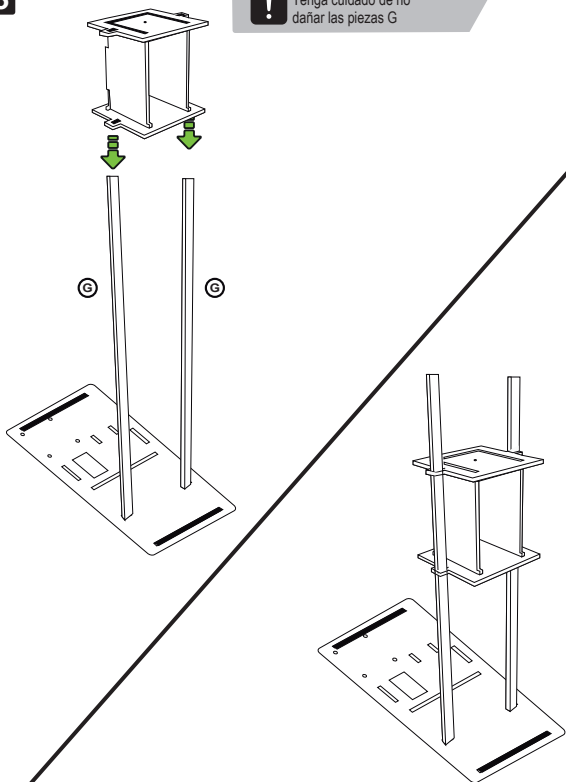

**6**

Coloque la pieza B atrás de la cabina. Utilice las piezas J como soporte

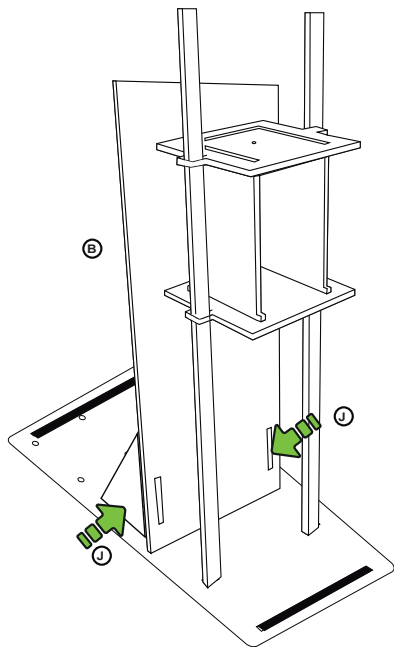

Coloque  
pegamento





**7**

Coloque la pieza M para asegurar la pieza B y las piezas G

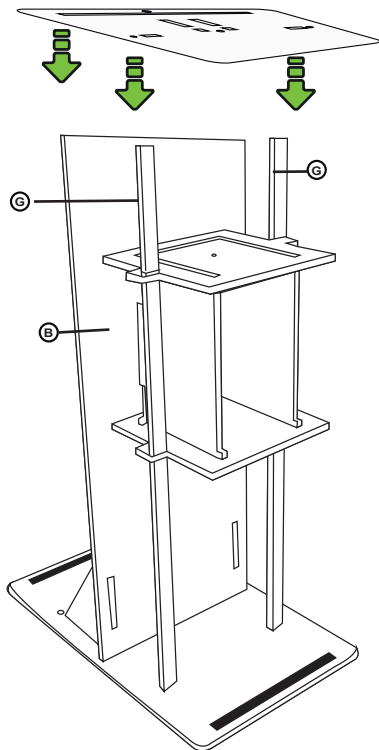

8

Coloque las piezas sobre M y G. Utilice tornillos U para asegurarlos junto con tuercas S

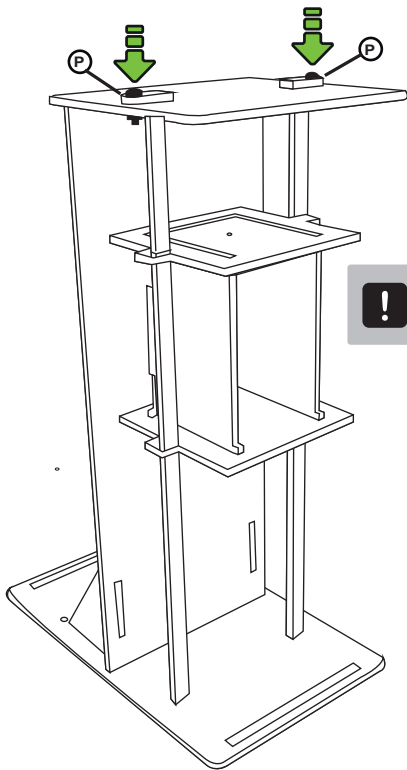

Coloque  
pegamento



Utilice pinzas y desarmador para apretar tornillos y tuercas.

## ARMADO DE POLEAS

- 9** Utilice 2 piezas L y coloque en medio la pieza I. En ambas orillas coloque piezas K, asegure todas las piezas con un tornillo T y tuerca S



No apriete mucho la tuerca porque la polea debe girar para que baje y suba la cabina del elevador

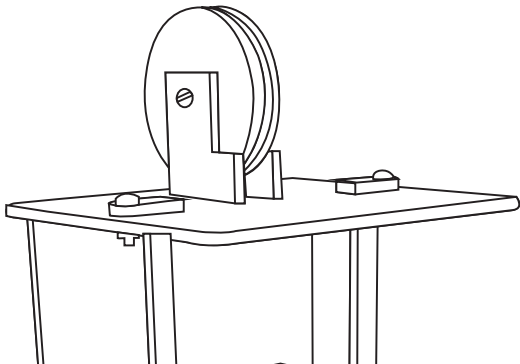

Utilice pinzas y desarmador para apretar tornillos y tuercas.

**10**

Tome la pieza O, pase el hilo V y haga un nudo asegurando la pieza O, en seguida pase el hilo por el orificio de la cabina y páselo por arriba de la polea hasta llegar a la pieza Ñ y amarrelo al agujero.

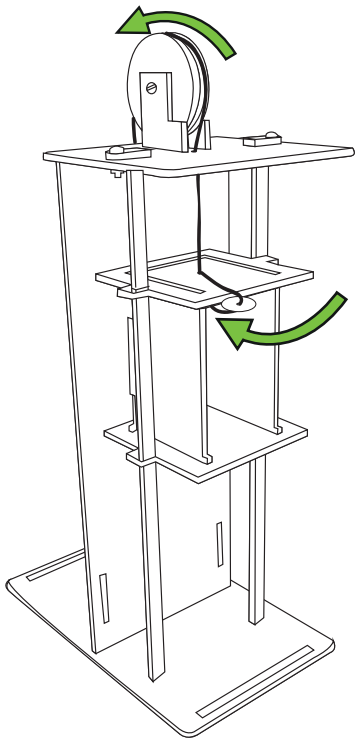

## ARMADO DE PCB

11

! Ponga atención a la polaridad de los cables

11A: Tome el cable dupont (R), corte un extremo y pele el cable, suelde en las terminales del motor, cada una en un extremo.

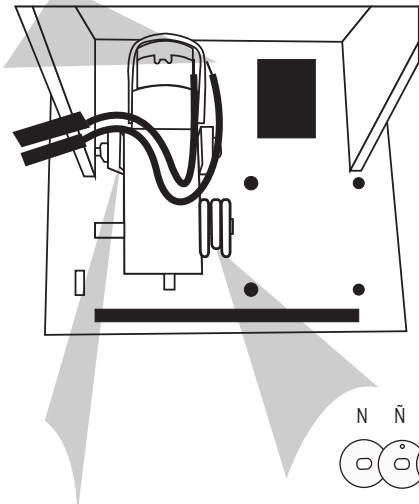

11B: Inserte las piezas H por debajo del chasis, péguelas y coloque el motor, asegúrelo con tornillos T y una tuerca Q abajo y otra S arriba

11C: Coloque las piezas N y Ñ como se muestra en la imagen, ponga la pieza Ñ en medio de las piezas N).

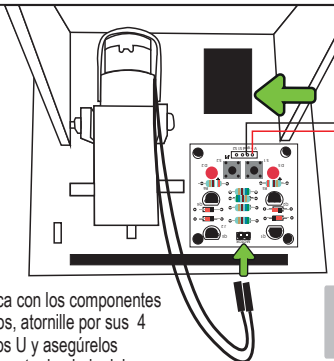
**12**

12D: Coloque una batería de 9 V en el orificio y conéctela al broche.

12C: Suelde los cables del broche de pila a la pieza J1, como se muestra en la imagen.

12A: Coloque la placa con los componentes previamente soldados, atornille por sus 4 extremos con tornillos U y asegúrelos con tuercas S por la parte de abajo del chasis.

12B: Conecte el cable dupont como se indica en la imagen.



Ponga atención a la polaridad de los cables

## FUNCIONAMIENTO

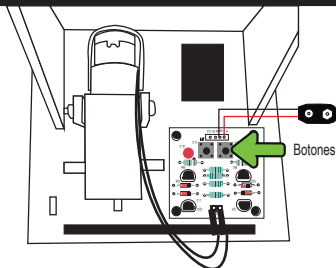

1. Mantenga presionado el botón de la izquierda para subir la cabina del elevador.
2. Mantenga presionado el botón de la derecha para bajar la cabina del elevador.

## ESPECIFICACIONES

Alimentación: 9V  $\text{---}$  (batería cuadrada)



[www.steren.com](http://www.steren.com)

# ELECTRONIC ELEVATOR KIT

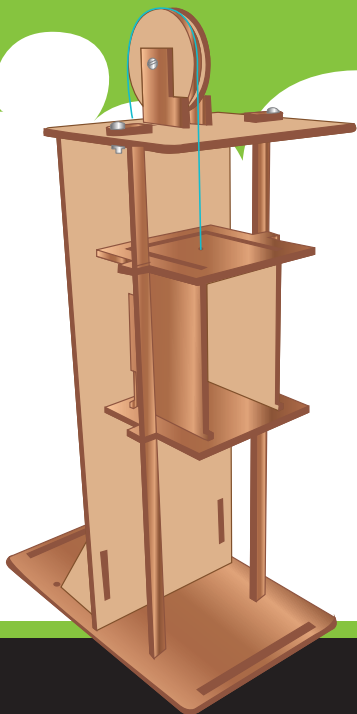



# IMPORTANT

Before using your new Steren product, read this manual to avoid any malfunction.

The information shown in this manual serves only as a reference for the product. Due to updates there may be differences. Please check our website [www.steren.com](http://www.steren.com) for the most recent version of the manual.

## CAUTIONS:

- DO NOT over tighten the screws to avoid damaging or breaking the parts.
- Be careful when assembling parts, DO NOT force them.
- Use wood glue to fix the joints of the assembly. Avoid placing glue on the moving parts.
- This device is not intended for use by persons (including children), whose physical, sensory or mental abilities are different or reduced, or lack experience or knowledge
- Children should be supervised to ensure they do not use the device as a toy.

## TOOLS NEEDED

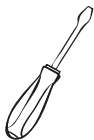

Flat screwdriver

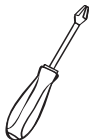

Cross screwdriver



Glue for wood









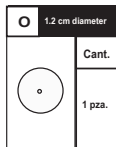
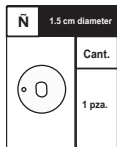
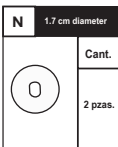
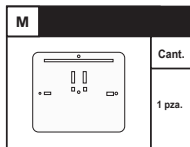
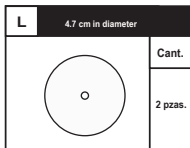
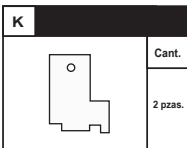
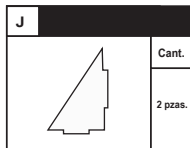
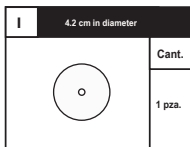
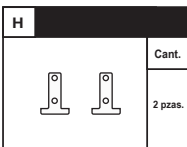
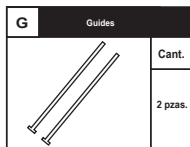
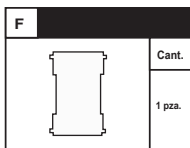
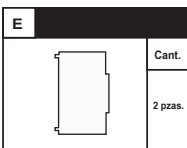
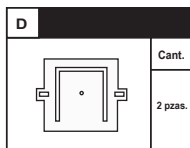
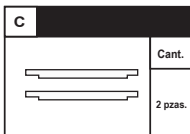
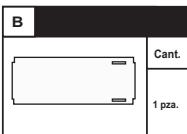
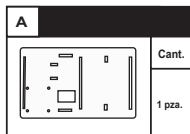

Tip tweezers

# CONTENT







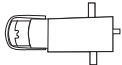

## PARTS OF THE CHASSIS

! Handle the parts with care, you can break easily



<b>P</b>							
		Cant.		<b>Q</b> Safety nut		Cant.	
		2 pzas.				1 pza.	
				<b>R</b> Dupont cable		Cant.	
						1 pza.	
				<b>S</b>		Cant.	
						8 pzas.	
<b>T</b> Large screw		Cant.		<b>U</b> Small screw		Cant.	
		3 pzas.				6 pzas.	
				<b>V</b> Nylon thread		Cant.	
						1 pza.	
				<b>W</b> Gearmotor		Cant.	
						1 pza.	

## ▶▶▶ CARD PARTS

<b>J2</b> Header		Cant.		<b>Q1 - Q4</b> Transistor 2N 2222		Cant.	
		1 pza.				4 pzas.	
				<b>J1</b> Stack brooch		Cant.	
						1 pza.	
				<b>R1 - R4</b> Resistance 560 (green, blue, coffee)		Cant.	
						4 pzas.	
<b>S1 - S2</b> Push type button		Cant.		<b>R5 - R6</b> Resistance 3K9 (orange, white, red)		Cant.	
		2 pzas.				2 pzas.	
				<b>D1 - D4</b> Diode 1N4148		Cant.	
						4 pzas.	
				<b>D5 - D6</b> Red LED		Cant.	
						2 pzas.	

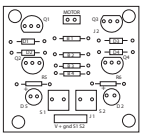
<b>PCB</b>	<b>Plate</b>	
		Cant.
		1 pza.



Assemble and weld the components of the plate as indicated in the image.

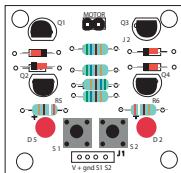

Some components have polarity be careful.

# ASSEMBLY

Start assembling from the base.



Be sure to place the correct parts before applying glue.

1

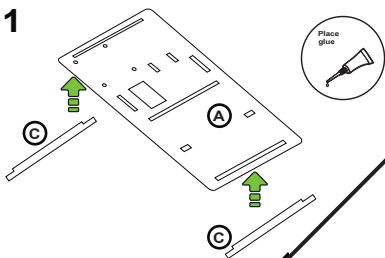

2

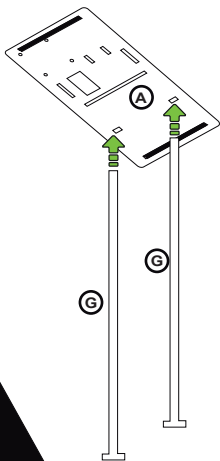

Pass the pieces G under piece A carefully.

3

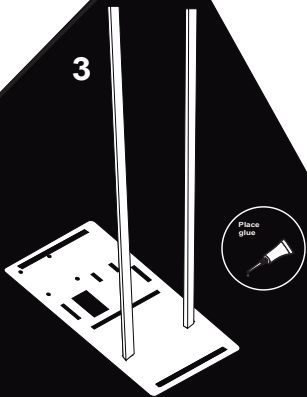

#### 4 Assemble the elevator cabin

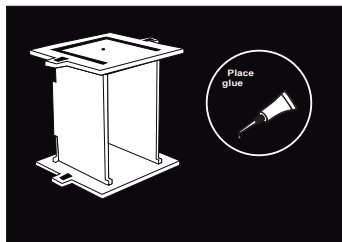
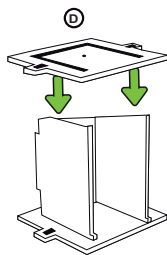
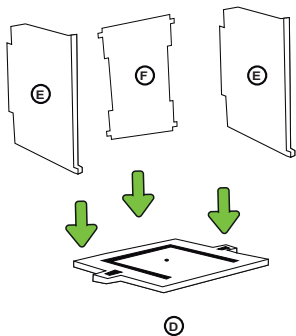

5

! Be careful not to damage the G pieces

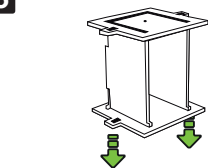

G

G

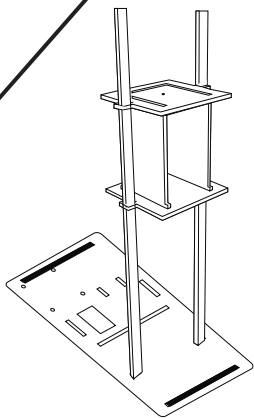
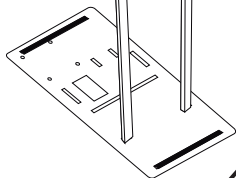

**6** Place part B behind the cab. Use the J pieces as support

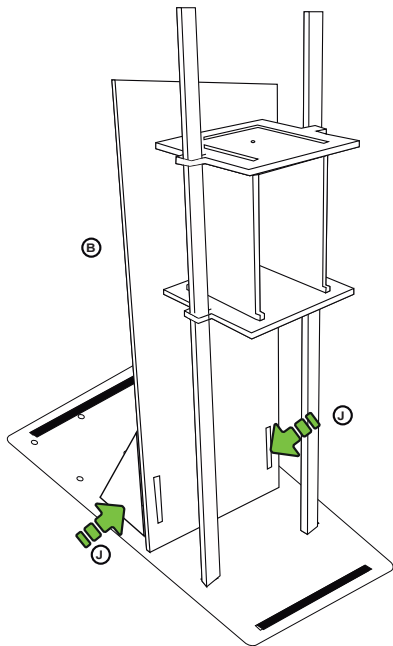

Place  
glue



**7**

Place part M to secure part B and parts G

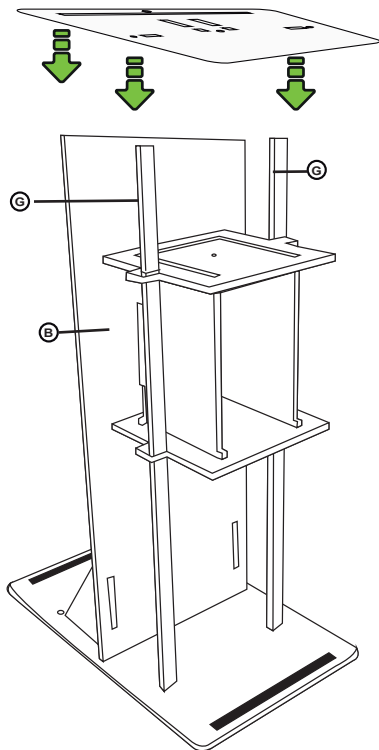



**8** Place part M to secure part B and parts G

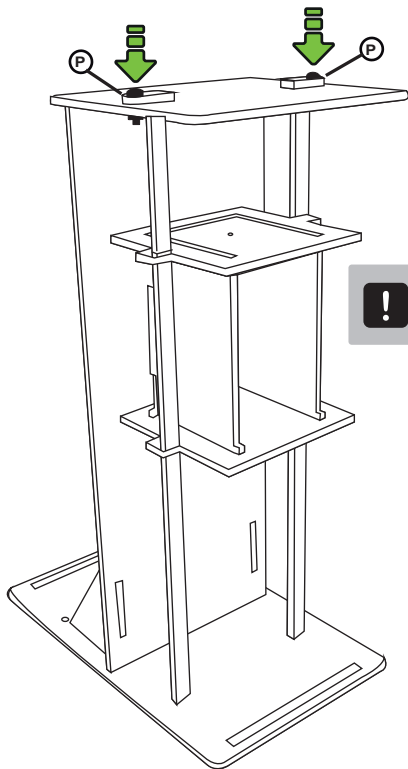

**!** Use pliers and screwdriver to tighten screws and nuts.

## ASSEMBLY OF PULLEYS

- 9** Use 2 pieces L and place the piece I in the middle. On both sides place pieces K, secure all the pieces with a screw T and nut S



Do not tighten the nut too much because the pulley must turn to lower and raise the cabin of the elevator

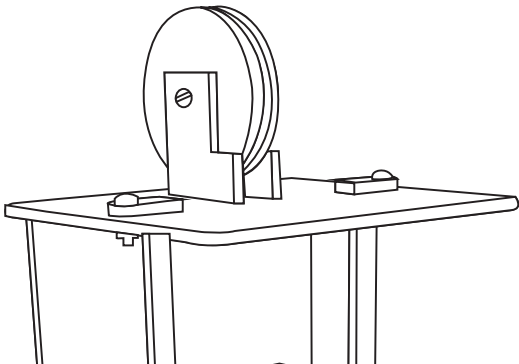

Use pliers and screwdriver to tighten screws and nuts.

**10**

Take piece O, pass thread V and tie a knot securing piece O, then pass the thread through the bore of the booth and pass it up from the pulley until you reach the Ñ part and tie it to the hole.

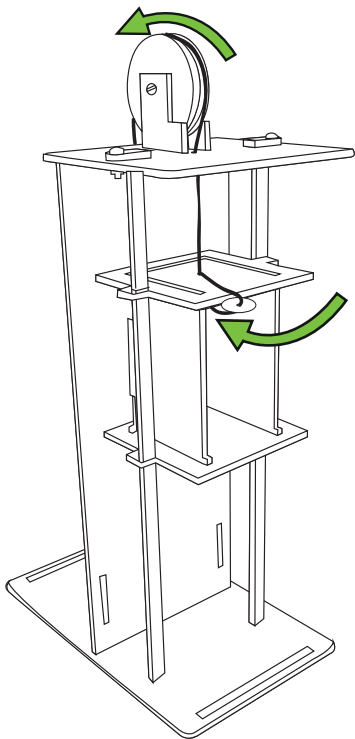

## ARMING OF PCB

11

! Pay attention to the polarity of the cables

11A: Take the dupont cable (R), cut one end and strip the cable, weld on the motor terminals, each one on one end.

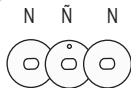
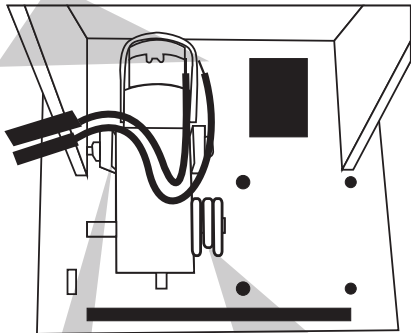

11B: Insert the parts H under the chassis, stick them and place the motor, secure it with screws T and a nut Q down and another S up

11C: Place the pieces N and Ñ  
As shown in the picture, put the piece Ñ in the middle of the pieces N).

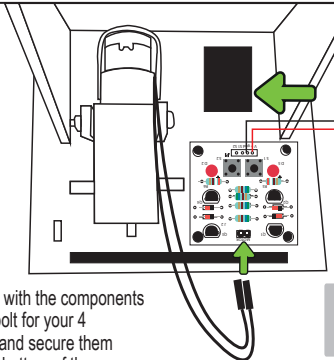
**12**

12D: Place one 9 V battery in the hole and connect it to brooch.

12C: Solder the cables of the battery clip or piece J1, as shows in the image.

12A: Place the plate with the components previously welded, bolt for your 4 ends with U screws and secure them with nuts S from the bottom of the chassis.

12B: Connect the dupont cable as indicated in the image.



Pay attention to the polarity of the cables

## FUNCTIONING

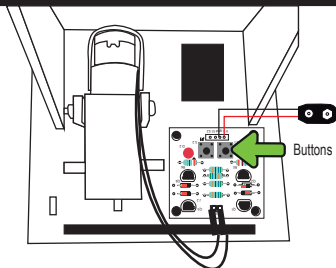

1. Press and hold the button on the left to raise the elevator car.
2. Press and hold the button on the right to lower the elevator cab.

## SPECIFICATIONS

Input: 9V  (square battery)



[www.steren.com](http://www.steren.com)